

LMS11

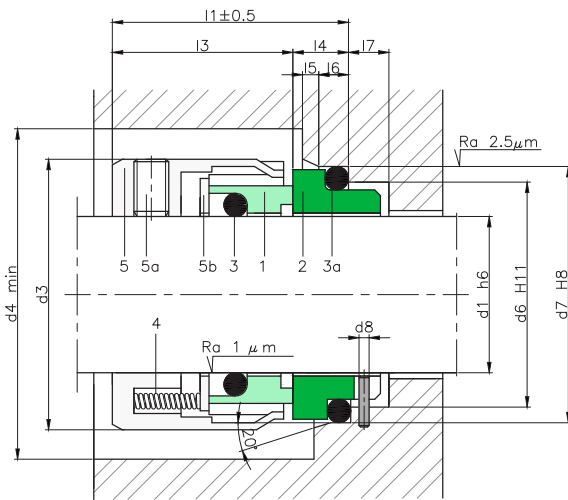

COMPONENTS:

- 1 Rotating contact surface
- 2 Stationary contact surface
- 3 O-rings
- 3a O-rings
- 4 Springs
- 5 Metal frame
- 5a Set screws
- 5b Ring



SECTORS:



CHARACTERISTICS:

- Unbalanced.
- System attached to the shaft by allen screws.
- Not dependent on the rotation direction.

OPERATING LIMITS:

$d_1 = 18 \div 100 \text{ mm}$ $p = 10 \text{ kg/cm}^2$

$v = 20 \text{ m/s}$ $t = -15 \div +200^\circ\text{C} (*)$

(*) The temperature resistance depends on the material of the secondary seals used.

The operating limits are defined by the PV factor which is determined for the sealing system characteristics and those of the application.

DESCRIPTION:

The contact surface of the rotating part can be detached, which makes this model extremely versatile as it is easy to exchange contact surfaces made of different materials.

Seal compliant with standard EN 12756.

DIMENSIONS CHART

Dimensions in mm

Shaft mm	Rotary part			Stationary part							Total length l ₁
	d ₃	d ₄	l ₃	d ₆	d ₇	d ₈	l ₄	l ₅	l ₆	l ₇	
18	32	37	21.0	27	33	3	10.0	2.0	4	9	31
20	34	39	21.0	29	35	3	10.0	2.0	5	9	31
22	36	41	21.0	31	37	3	10.0	2.0	5	9	31
24	38	43	24.0	33	39	3	10.0	2.0	5	9	34
25	39	44	24.0	34	40	3	10.0	2.0	5	9	34
28	42	47	24.0	37	43	3	10.0	2.0	5	9	34
30	44	49	25.0	39	45	3	10.0	2.0	5	9	35
32	46	51	25.0	42	48	3	10.0	2.0	5	9	35
33	47	52	25.0	42	48	3	10.0	2.0	5	9	35
35	49	54	25.0	44	50	3	10.0	2.0	5	9	35
38	54	59	28.0	49	56	4	11.0	2.0	6	9	39
40	56	61	28.0	51	58	4	11.0	2.0	6	9	39
43	59	64	28.0	54	61	4	11.0	2.0	6	9	39
45	61	66	28.0	56	63	4	11.0	2.0	6	9	39
48	64	69	28.0	59	66	4	11.0	2.0	6	9	39
50	66	71	28.0	62	70	4	13.0	2.5	6	9	41
53	69	74	28.0	65	73	4	13.0	2.5	6	9	41
55	71	76	28.0	67	75	4	13.0	2.5	6	9	41
58	78	83	29.0	70	78	4	13.0	2.5	6	9	42
60	80	85	29.0	72	80	4	13.0	2.5	6	9	42
63	83	88	32.0	75	83	4	13.0	2.5	6	9	45
65	85	90	32.0	77	85	4	13.0	2.5	6	9	45
68	88	93	32.7	81	90	4	15.3	2.5	7	9	48
70	90	95	32.7	83	92	4	15.3	2.5	7	9	48
75	99	104	36.7	88	97	4	15.3	2.5	7	9	52
80	104	109	36.3	95	105	4	15.7	3.0	7	9	52
85	109	114	36.3	100	110	4	15.7	3.0	7	9	52
90	114	119	39.3	105	115	4	15.7	3.0	7	9	55
95	119	124	39.3	110	120	4	15.7	3.0	7	9	55
100	124	129	39.3	115	125	4	15.7	3.0	7	9	55

Dimensions subject to changes or modifications.